

Optically Controlled Multi-Channel Transmitter with RF Monitoring Feedback

Gudino N, de Zwart JA, van Gelderen P, Duyn JH

Advanced MRI Section, LFMI, NINDS, National Institutes of Health, Bethesda, Maryland, USA

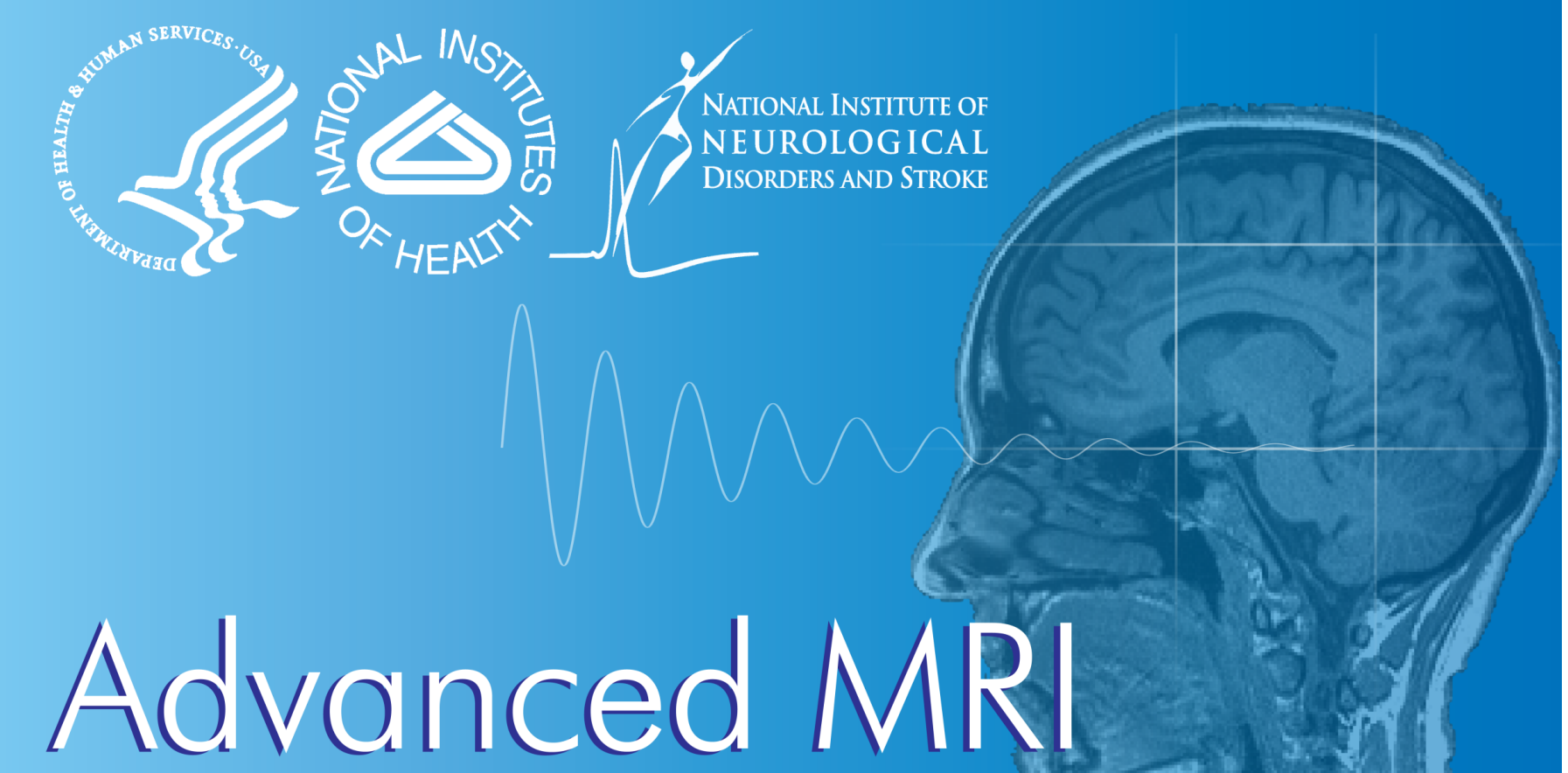

Introduction

Clinical implementation of multi-channel TX systems has been slow due to tissue heating concerns. Accurate and rapid control of amplitude and phase of the individual transmit channels is necessary to predict B_1 -related tissue heating patterns¹⁻³. To this end, we present a four-channel transceiver array for 7T imaging built from optically-controlled on-coil amplifiers^{4,5} with optical real-time RF signal monitoring^{3,6}. Using this monitored feedback signal, the system can be turned off in the event of a hardware failure. The feedback can also be used to correct nonlinearities of the hardware and perform automatic calibrations. We present preliminary data to evaluate system performance.

Methods and Results

Hardware Design: A new optically controlled on-coil amplifier is presented that delivers up to 100 W peak power and of which RF output can be monitored through a single optical fiber (Figure 1). The transmit signal is sensed by a loop integrated in an inner layer of the amplifier PCB. It is down converted, digitized and optically transmitted to a remote computer through a dedicated SPI-to-USB interface⁶. Transmit-receive operation was made possible by connecting a custom TX-RX switch and LNA board to each element⁷. Signal was received via the standard coil interface on the patient table. The amplifiers were controlled by a custom pTx interface based on vector modulation that generates four optical carrier and envelope signals of which phase and amplitude are controlled from a Linux computer. A four channel on-coil transceiver prototype was built with 6 cm diameter loops (Figure 2).

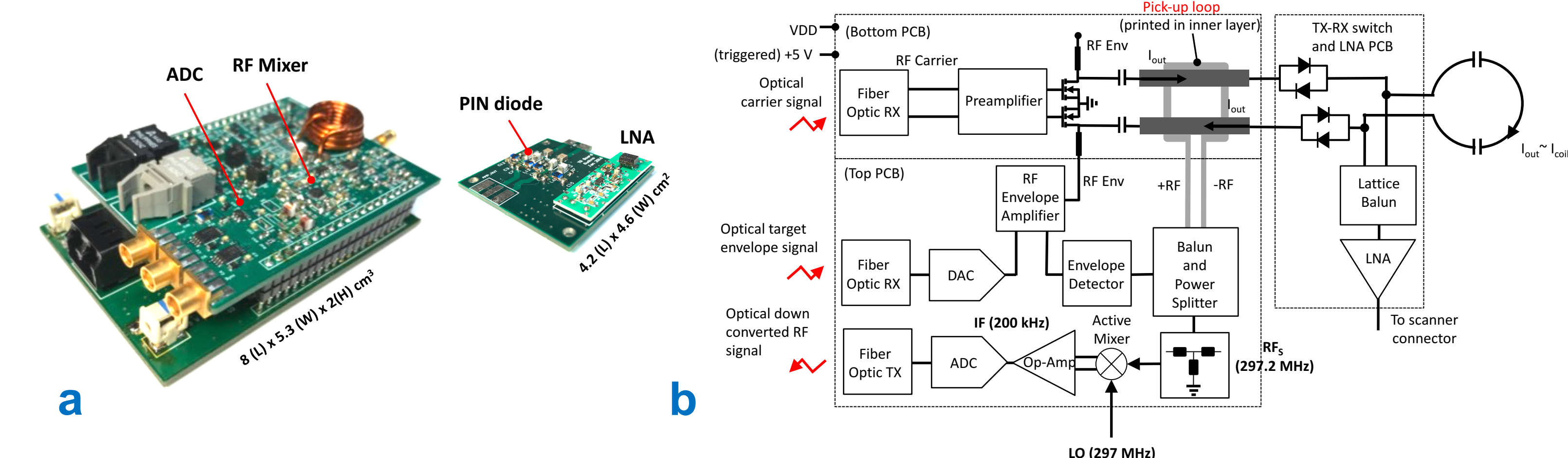
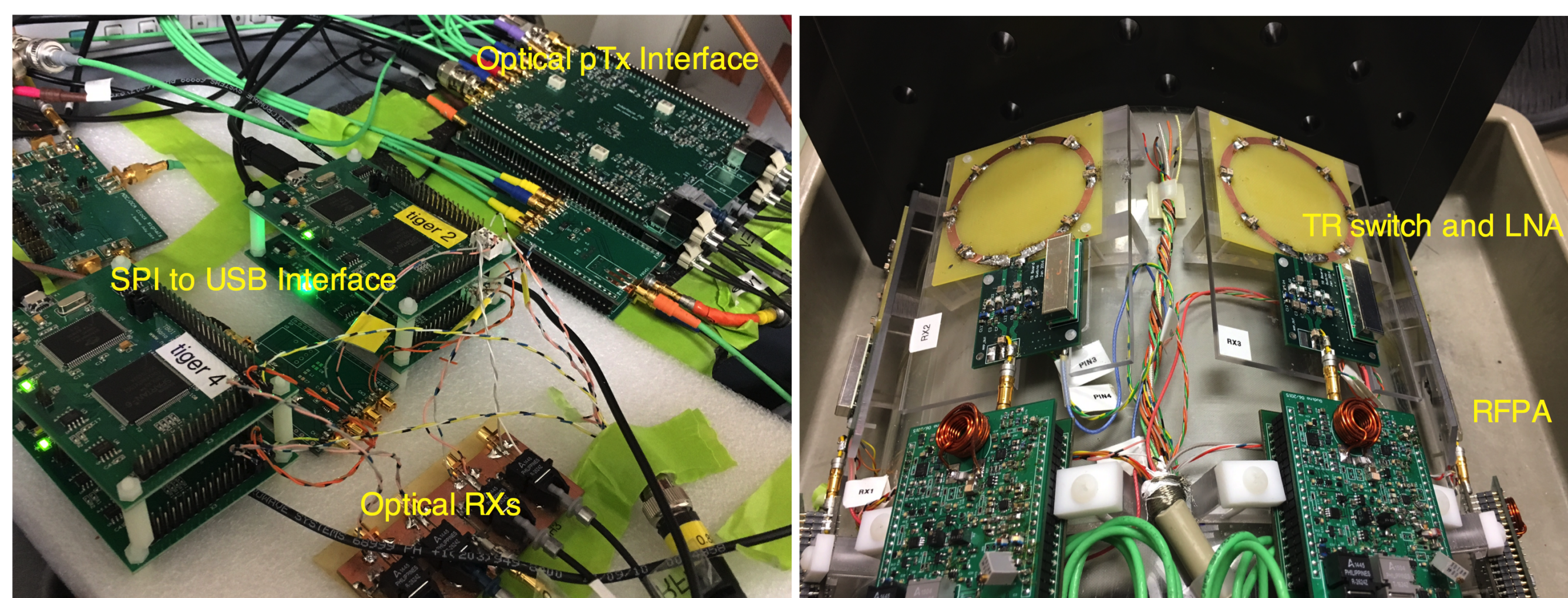

Figure 1: (a) New on coil amplifier with RF monitoring electronics and miniaturized TX-RX switch-LNA board. (b) Schematic of amplifier connected to coil through TX-RX switch.

Figure 2: Four-channel optical interface, optical RXs and SPI-to-USB interface for feedback signal monitoring (left). On-coil TX-RX array (right).



Safety feedback: Based on the monitored feedback signal, a custom user interface allows two modes of operation: safety monitoring and feedback/calibration. An initial safety-monitoring test was performed by adding a perturbation of the transmit signal by tuning an external loop, located closed to channel 1, with a PIN diode signal (detune) in sync with the RF unblank (Figure 3a). For this test, if a set threshold was exceeded the baseband control of all vector modulators (I,Q) would be automatically set for maximum RF amplitude attenuation.

Figure 3b shows the monitored RF pulse of each channel for consecutive repetition times before and after the disturbance created by synchronous tuning of the external loop. The RF amplitude of all channels was automatically set to zero after two TR cycles (100 ms). Data collection, processing and applying updated amplitude and phase for one channel took 14.7 ms after acquisition of the RF pulse (SD=2.8 ms for 248 repetitions).

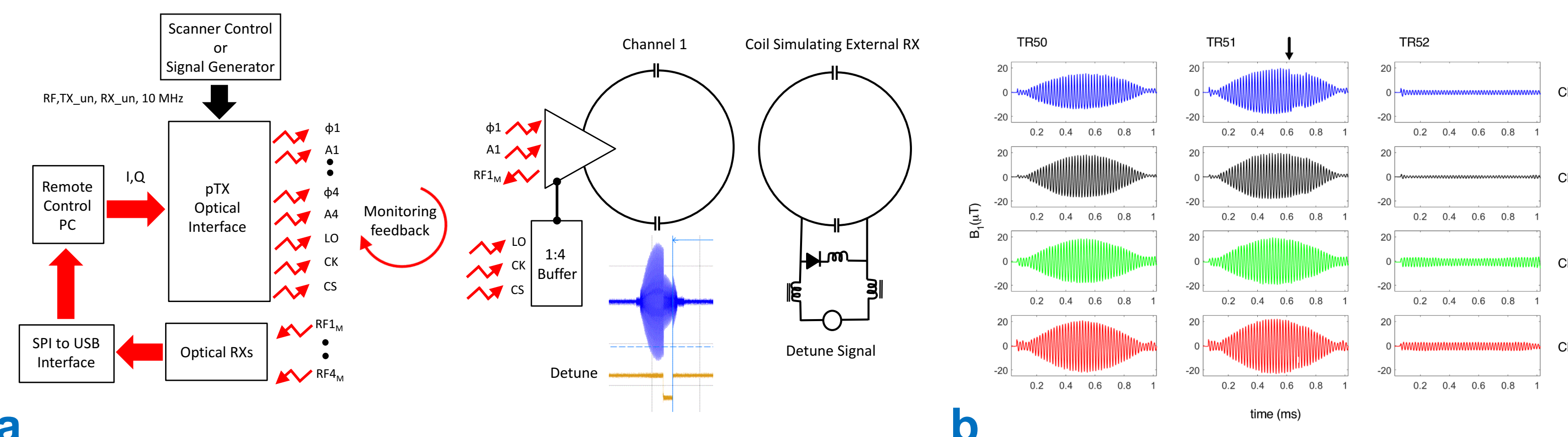
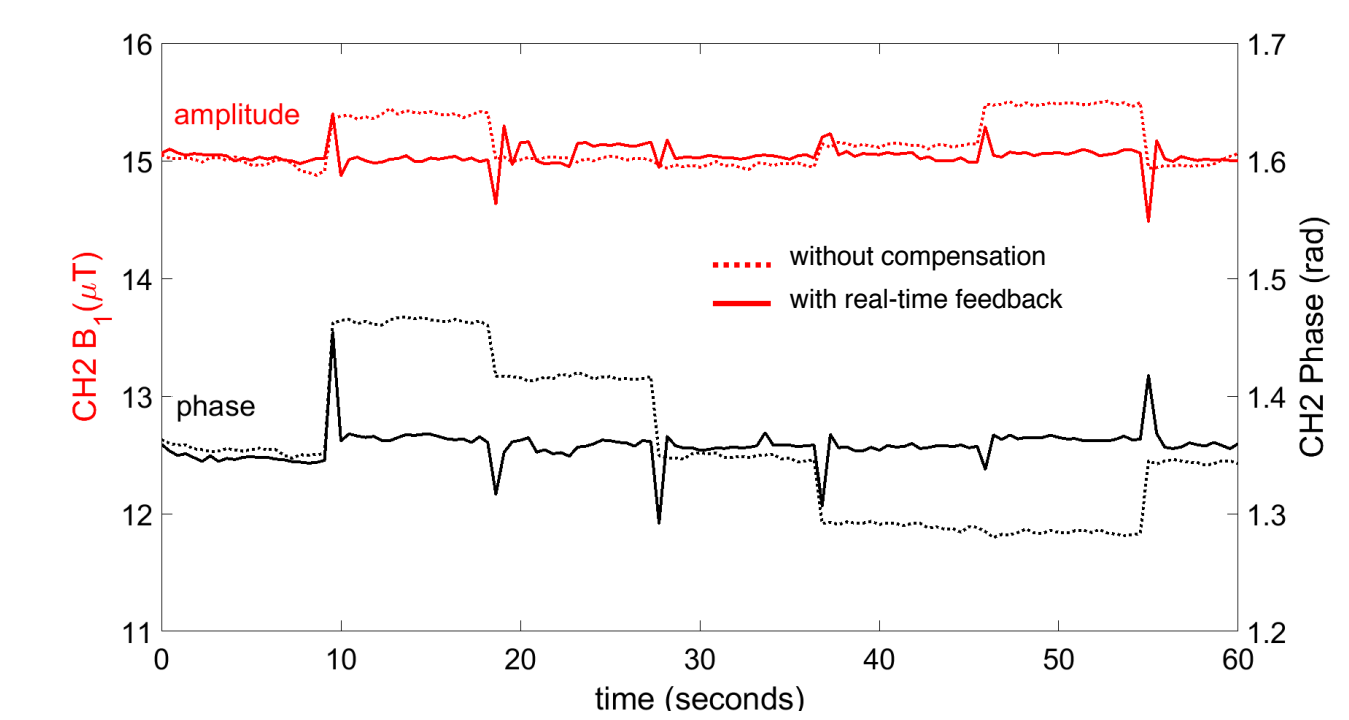
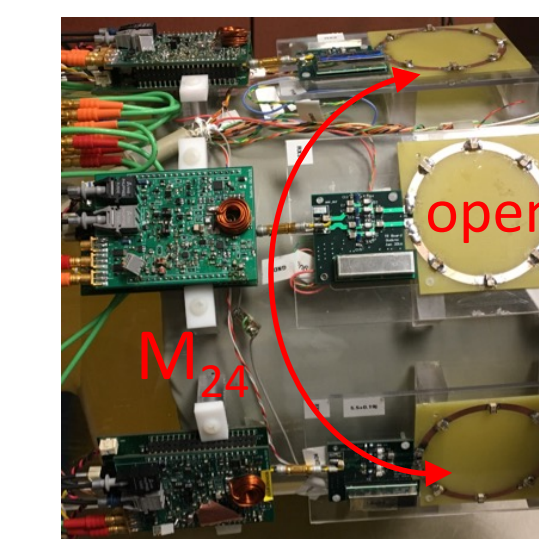

Figure 3: Safety system shutdown under the event of coupling to external loop. (a) Optical RF monitoring setup. The B_1 field on channel 1 (in blue) is distorted during the induced detuning failure of external loop. (b) Monitored RF transmit signals at different TRs before and after the perturbation was induced in channel 1.

System performance feedback: A feedback test was performed to demonstrate compensating for amplitude and phase deviations due to residual coupling between a pair of next neighbor channels. Amplitude and phase of both channels were monitored while the phase on one channel was incremented $\pi/4$ degrees every 10 seconds. Figure 4 shows the amplitude and phase of channel 2 without compensation (dotted line) and with the real-time feedback compensation (solid line) for the residual coupling with channel 4.

Figure 4: Compensation of residual coupling between the channels shown in picture. Monitored amplitude and phase on channel 2 while the phase of channel 4 was changed in increments of $\pi/4$ every 10 seconds without and with real-time compensation.



MRI and monitoring: The new hardware was tested in a 7T scanner. Images of a large oil phantom were acquired with a GRE sequence, 1 ms windowed sinc pulse, TR/TE= 250/5.44 ms, FOV= 343 x 343 mm, matrix size 128 x 128 and slice thickness 5 mm. The RF transmit signal per channel was monitored. An image of the oil phantom was successfully acquired when transmitting with the 4-channel with phase differences for CP excitation (Figure 5).

Figure 5: MRI of the large oil phantom and corresponding RF monitored signals obtained in the 7T scanner. The spurious spikes in channel 3 are due to 1-bit shift in the digitized monitored signal.

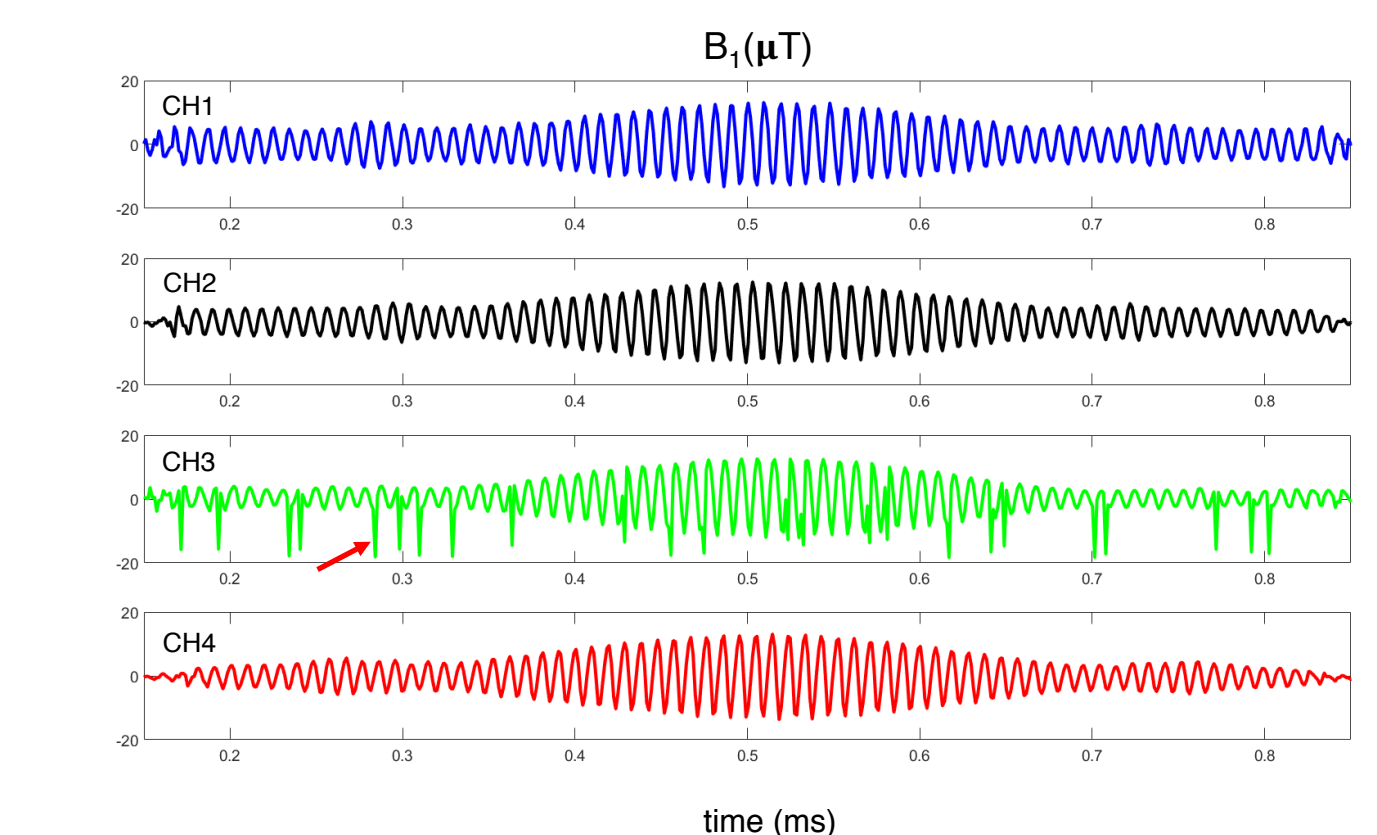
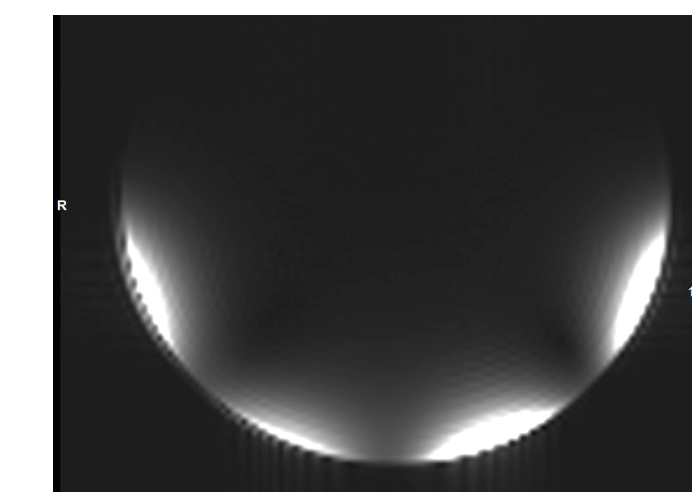

Discussion

We demonstrated a 4 channel transmitter based on optically controlled on-coil amplifiers with RF signal monitoring and feedback. This TX setup (together with electromagnetic field predictions) will allow accurate SAR supervision, help to ensure safety under the possibility of hardware failures, improve system performance by correcting nonlinearities of the hardware and perform automatic calibrations in the scanner.

References:

- Lee J et al. MRM. 2012 Jun;67:1566-78.
- Graesslin et al. ISMRM 15th,2007 (Abstract 1086).
- Graesslin I, et al. MRM. 2015 Aug 74:589-98
- Gudino N, et al. MRM. 2013 70:276-89.
- Gudino N, et al. MRM. 2016 76:340-9.
- Gudino N, et al. MRM 2017 [Epub ahead of print].
- Gudino N, et al. ISMRM 26th, 2017 (Abstract 2672).

